

Understanding Quadrilaterals



CHAPTER 3

3.1 Introduction

You know that the paper is a model for a **plane surface**. When you join a number of points without lifting a pencil from the paper (and without retracing any portion of the drawing other than single points), you get a **plane curve**.

Try to recall different varieties of curves you have seen in the earlier classes.

Match the following: (Caution! A figure may match to more than one type).

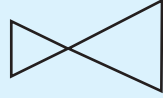
Figure	Type
(1) 	(a) Simple closed curve
(2) 	(b) A closed curve that is not simple
(3) 	(c) Simple curve that is not closed
(4) 	(d) Not a simple curve

Compare your matchings with those of your friends. Do they agree?

3.2 Polygons

A simple closed curve made up of only line segments is called a **polygon**.

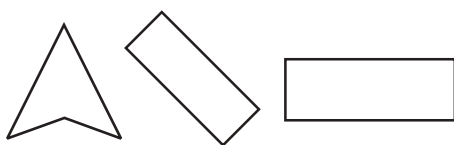

Curves that are polygons

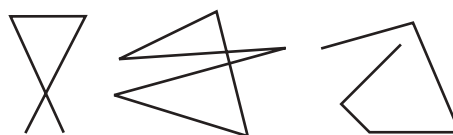





Curves that are not polygons

Try to give a few more examples and non-examples for a polygon.
 Draw a rough figure of a polygon and identify its sides and vertices.

3.2.1 Classification of polygons

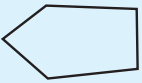
We classify polygons according to the number of sides (or vertices) they have.

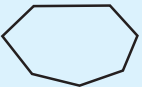
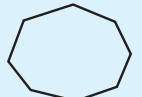
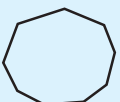
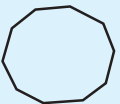
Number of sides or vertices	Classification	Sample figure
3	Triangle	
4	Quadrilateral	
5	Pentagon	
6	Hexagon	
7	Heptagon	
8	Octagon	
9	Nonagon	
10	Decagon	
⋮	⋮	⋮
n	n -gon	

3.2.2 Diagonals

A **diagonal** is a line segment connecting two non-consecutive vertices of a polygon (Fig 3.1).

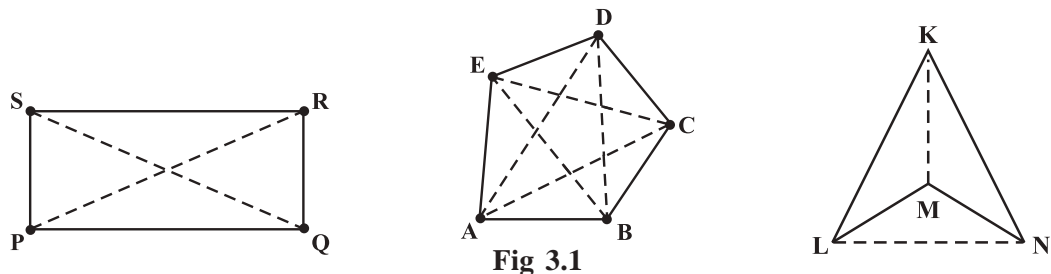
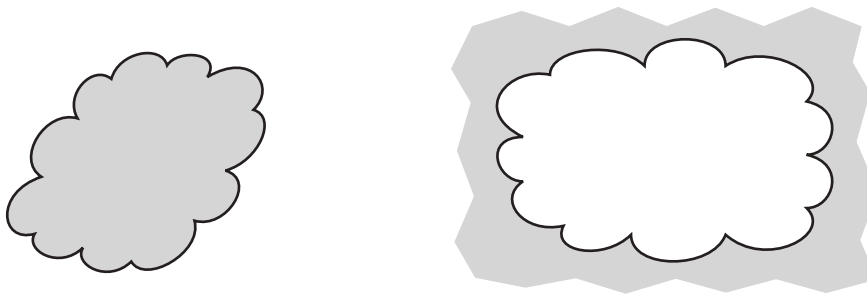

Fig 3.1

Can you name the diagonals in each of the above figures? (Fig 3.1)

Is \overline{PQ} a diagonal? What about \overline{LN} ?

You already know what we mean by **interior** and **exterior** of a closed curve (Fig 3.2).



Interior

Fig 3.2

Exterior

The interior has a boundary. Does the exterior have a boundary? Discuss with your friends.

3.2.3 Convex and concave polygons

Here are some convex polygons and some concave polygons. (Fig 3.3)

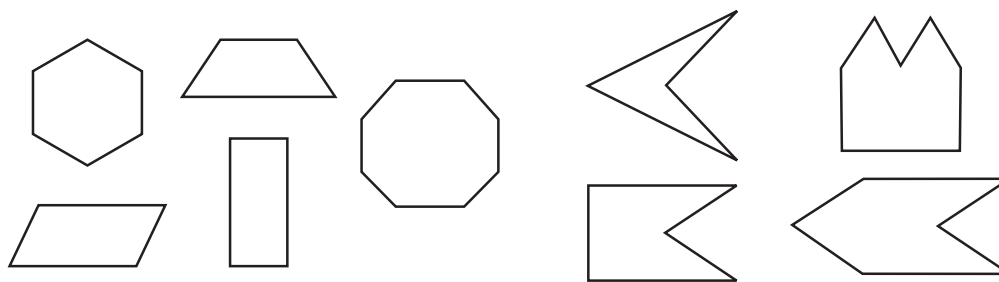

Convex polygons

Fig 3.3

Concave polygons

Can you find how these types of polygons differ from one another? Polygons that are convex have no portions of their diagonals in their exteriors. Is this true with concave polygons? Study the figures given. Then try to describe in your own words what we mean by a convex polygon and what we mean by a concave polygon. Give two rough sketches of each kind. In our work in this class, we will be dealing with convex polygons only.

3.2.4 Regular and irregular polygons

A regular polygon is both 'equiangular' and 'equilateral'. For example, a square has sides of equal length and angles of equal measure. Hence it is a regular polygon. A rectangle is equiangular but not equilateral. Is a rectangle a regular polygon? Is an equilateral triangle a regular polygon? Why?

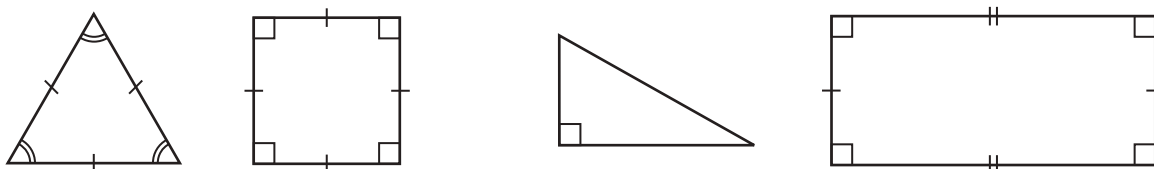

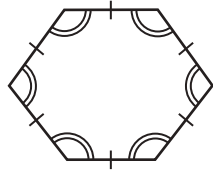
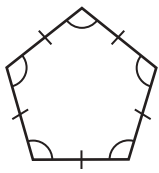

Regular polygons

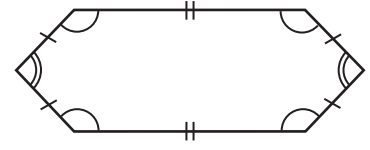
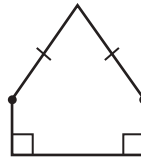

Polygons that are not regular

[Note: Use of \sphericalangle or \sphericalangle indicates segments of equal length].

In the previous classes, have you come across any quadrilateral that is equilateral but not equiangular? Recall the quadrilateral shapes you saw in earlier classes – Rectangle, Square, Rhombus etc.

Is there a triangle that is equilateral but not equiangular?

3.2.5 Angle sum property

Do you remember the angle-sum property of a triangle? The sum of the measures of the three angles of a triangle is 180° . Recall the methods by which we tried to visualise this fact. We now extend these ideas to a quadrilateral.

DO THIS



1. Take any quadrilateral, say ABCD (Fig 3.4). Divide it into two triangles, by drawing a diagonal. You get six angles 1, 2, 3, 4, 5 and 6.

Use the angle-sum property of a triangle and argue how the sum of the measures of $\angle A$, $\angle B$, $\angle C$ and $\angle D$ amounts to $180^\circ + 180^\circ = 360^\circ$.

2. Take four congruent card-board copies of any quadrilateral ABCD, with angles as shown [Fig 3.5 (i)]. Arrange the copies as shown in the figure, where angles $\angle 1$, $\angle 2$, $\angle 3$, $\angle 4$ meet at a point [Fig 3.5 (ii)].

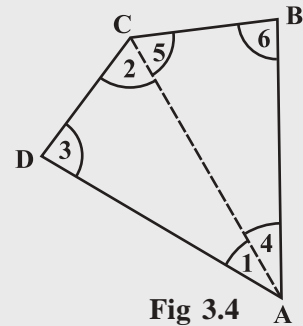
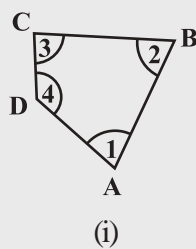
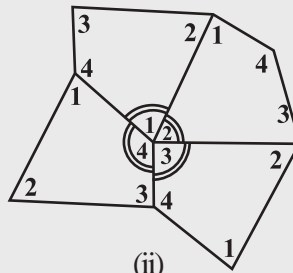

Fig 3.4



(i)



(ii)

Fig 3.5

For doing this you may have to turn and match appropriate corners so that they fit.

What can you say about the sum of the angles $\angle 1$, $\angle 2$, $\angle 3$ and $\angle 4$?

[Note: We denote the angles by $\angle 1$, $\angle 2$, $\angle 3$, etc., and their respective measures by $m\angle 1$, $m\angle 2$, $m\angle 3$, etc.]

The sum of the measures of the four angles of a quadrilateral is _____.

You may arrive at this result in several other ways also.

- As before consider quadrilateral ABCD (Fig 3.6). Let P be any point in its interior. Join P to vertices A, B, C and D. In the figure, consider ΔPAB . From this we see $x = 180^\circ - m\angle 2 - m\angle 3$; similarly from ΔPBC , $y = 180^\circ - m\angle 4 - m\angle 5$, from ΔPCD , $z = 180^\circ - m\angle 6 - m\angle 7$ and from ΔPDA , $w = 180^\circ - m\angle 8 - m\angle 1$. Use this to find the total measure $m\angle 1 + m\angle 2 + \dots + m\angle 8$, does it help you to arrive at the result? Remember $\angle x + \angle y + \angle z + \angle w = 360^\circ$.
- These quadrilaterals were convex. What would happen if the quadrilateral is not convex? Consider quadrilateral ABCD. Split it into two triangles and find the sum of the interior angles (Fig 3.7).

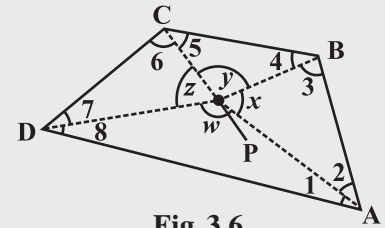

Fig 3.6

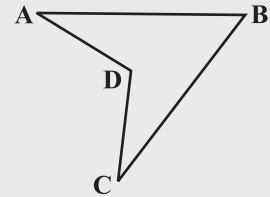

Fig 3.7

EXERCISE 3.1

- Given here are some figures.



(1)

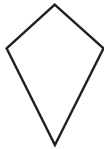

(2)

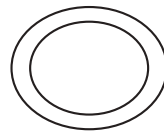

(3)



(4)

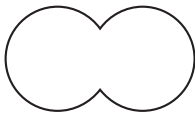

(5)



(6)



(7)



(8)

Classify each of them on the basis of the following.

- Simple curve
 - Simple closed curve
 - Polygon
 - Convex polygon
 - Concave polygon
- How many diagonals does each of the following have?
 - A convex quadrilateral
 - A regular hexagon
 - A triangle
 - What is the sum of the measures of the angles of a convex quadrilateral? Will this property hold if the quadrilateral is not convex? (Make a non-convex quadrilateral and try!)
 - Examine the table. (Each figure is divided into triangles and the sum of the angles deduced from that.)

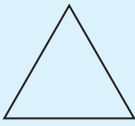
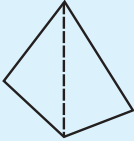
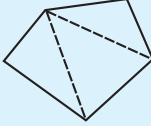
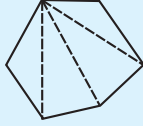
Figure				
Side	3	4	5	6
Angle sum	180°	$2 \times 180^\circ$ $= (4 - 2) \times 180^\circ$	$3 \times 180^\circ$ $= (5 - 2) \times 180^\circ$	$4 \times 180^\circ$ $= (6 - 2) \times 180^\circ$



What can you say about the angle sum of a convex polygon with number of sides?

- (a) 7 (b) 8 (c) 10 (d) n

5. What is a regular polygon?

State the name of a regular polygon of

- (i) 3 sides (ii) 4 sides (iii) 6 sides

6. Find the angle measure x in the following figures.

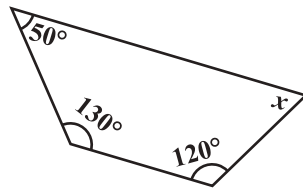

(a)

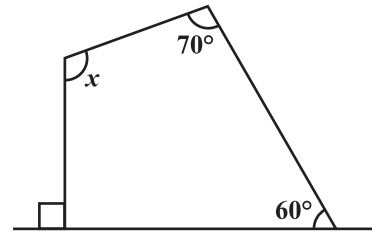

(b)

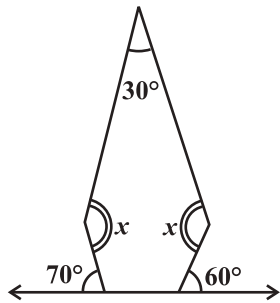

(c)

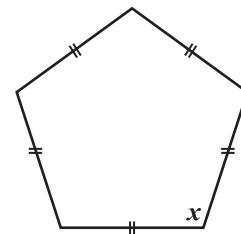

(d)

7.

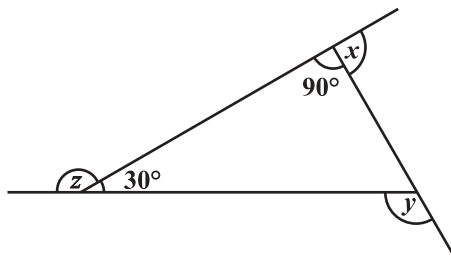

(a) Find $x + y + z$

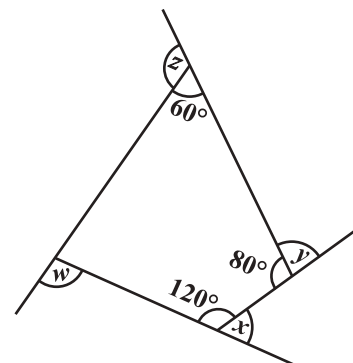

(b) Find $x + y + z + w$

3.3 Sum of the Measures of the Exterior Angles of a Polygon

On many occasions a knowledge of exterior angles may throw light on the nature of interior angles and sides.

DO THIS

Draw a polygon on the floor, using a piece of chalk. (In the figure, a pentagon ABCDE is shown) (Fig 3.8).

We want to know the total measure of angles, i.e., $m\angle 1 + m\angle 2 + m\angle 3 + m\angle 4 + m\angle 5$. Start at A. Walk along \overline{AB} . On reaching B, you need to turn through an angle of $m\angle 1$, to walk along \overline{BC} . When you reach at C, you need to turn through an angle of $m\angle 2$ to walk along \overline{CD} . You continue to move in this manner, until you return to side AB. You would have in fact made one complete turn.

Therefore, $m\angle 1 + m\angle 2 + m\angle 3 + m\angle 4 + m\angle 5 = 360^\circ$
This is true whatever be the number of sides of the polygon.

Therefore, *the sum of the measures of the exterior angles of any polygon is 360° .*

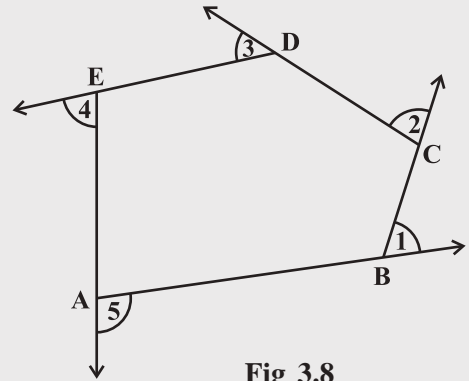

Fig 3.8

Example 1: Find measure x in Fig 3.9.

Solution: $x + 90^\circ + 50^\circ + 110^\circ = 360^\circ$ (Why?)
 $x + 250^\circ = 360^\circ$
 $x = 110^\circ$

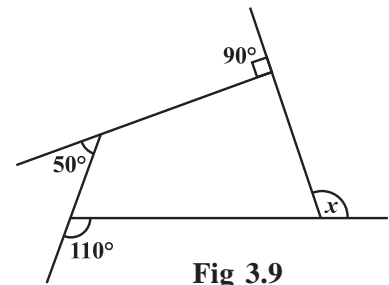

Fig 3.9

TRY THESE

Take a regular hexagon Fig 3.10.

1. What is the sum of the measures of its exterior angles x, y, z, p, q, r ?
2. Is $x = y = z = p = q = r$? Why?
3. What is the measure of each?
 - (i) exterior angle
 - (ii) interior angle
4. Repeat this activity for the cases of
 - (i) a regular octagon
 - (ii) a regular 20-gon

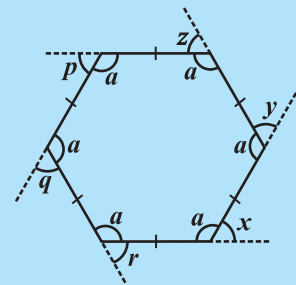

Fig 3.10

Example 2: Find the number of sides of a regular polygon whose each exterior angle has a measure of 45° .

Solution: Total measure of all exterior angles = 360°
Measure of each exterior angle = 45°

Therefore, the number of exterior angles = $\frac{360}{45} = 8$

The polygon has 8 sides.



EXERCISE 3.2

1. Find x in the following figures.

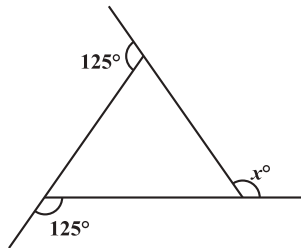

(a)

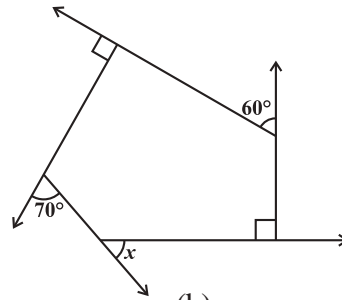

(b)

2. Find the measure of each exterior angle of a regular polygon of
 - (i) 9 sides
 - (ii) 15 sides
3. How many sides does a regular polygon have if the measure of an exterior angle is 24° ?
4. How many sides does a regular polygon have if each of its interior angles is 165° ?
5. (a) Is it possible to have a regular polygon with measure of each exterior angle as 22° ?
 (b) Can it be an interior angle of a regular polygon? Why?
6. (a) What is the minimum interior angle possible for a regular polygon? Why?
 (b) What is the maximum exterior angle possible for a regular polygon?

3.4 Kinds of Quadrilaterals

Based on the nature of the sides or angles of a quadrilateral, it gets special names.

3.4.1 Trapezium

Trapezium is a quadrilateral with a pair of parallel sides.

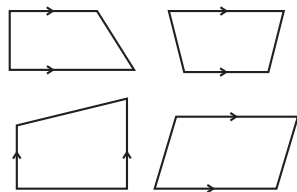

These are trapeziums

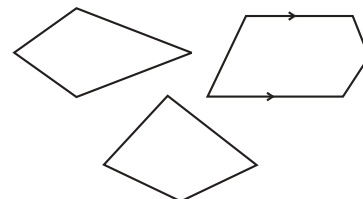

These are not trapeziums

Study the above figures and discuss with your friends why some of them are trapeziums while some are not. (**Note:** The arrow marks indicate parallel lines).

DO THIS



1. Take identical cut-outs of congruent triangles of sides 3 cm, 4 cm, 5 cm. Arrange them as shown (Fig 3.11).

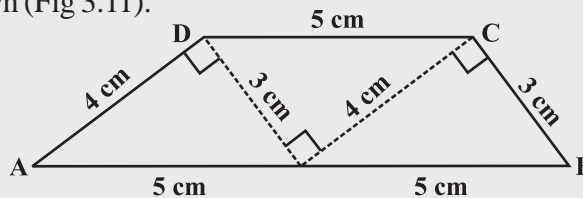

Fig 3.11

You get a trapezium. (Check it!) Which are the parallel sides here? Should the non-parallel sides be equal?

You can get two more trapeziums using the same set of triangles. Find them out and discuss their shapes.

- Take four set-squares from your and your friend's instrument boxes. Use different numbers of them to place side-by-side and obtain different trapeziums. If the non-parallel sides of a trapezium are of equal length, we call it an *isosceles trapezium*. Did you get an isosceles trapezium in any of your investigations given above?

3.4.2 Kite

Kite is a special type of a quadrilateral. The sides with the same markings in each figure are equal. For example $AB = AD$ and $BC = CD$.

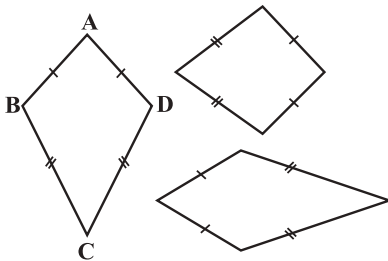

These are kites

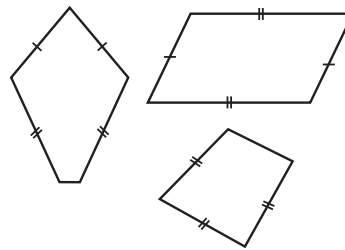

These are not kites

Study these figures and try to describe what a kite is. Observe that

- A kite has 4 sides (It is a quadrilateral).
- There are exactly two **distinct consecutive pairs** of sides of equal length.

DO THIS

Take a thick white sheet.

Fold the paper once.

Draw two line segments of different lengths as shown in Fig 3.12.

Cut along the line segments and open up.

You have the shape of a kite (Fig 3.13).

Has the kite any line symmetry?

Fold both the diagonals of the kite. Use the set-square to check if they cut at right angles. Are the diagonals equal in length?

Verify (by paper-folding or measurement) if the diagonals bisect each other.

By folding an angle of the kite on its opposite, check for angles of equal measure.

Observe the diagonal folds; do they indicate any diagonal being an angle bisector?

Share your findings with others and list them. A summary of these results are given elsewhere in the chapter for your reference.

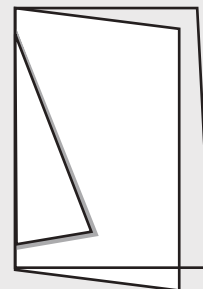

Fig 3.12

Show that $\triangle ABC$ and $\triangle ADC$ are congruent. What do we infer from this?

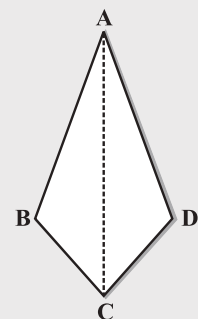
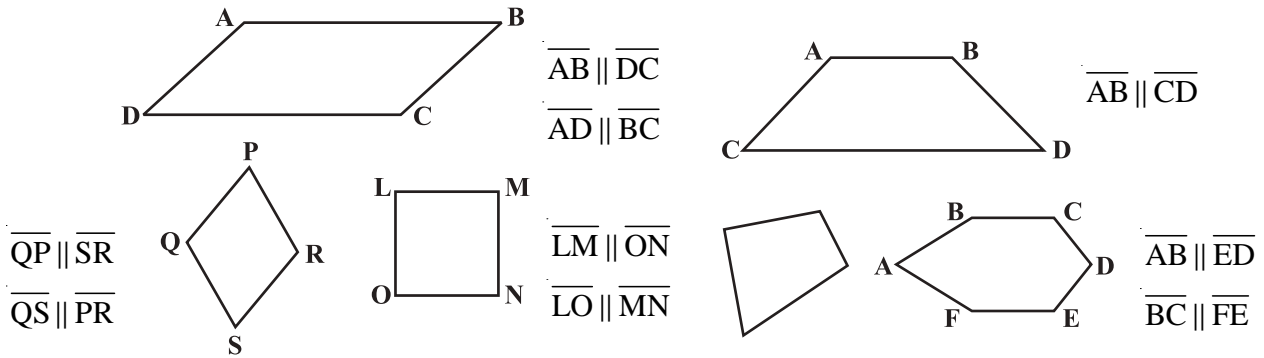

Fig 3.13

3.4.3 Parallelogram

A parallelogram is a quadrilateral. As the name suggests, it has something to do with parallel lines.



These are parallelograms

These are not parallelograms

Study these figures and try to describe in your own words what we mean by a parallelogram. Share your observations with your friends.

DO THIS



Take two different rectangular cardboard strips of different widths (Fig 3.14).



Strip 1

Fig 3.14

Strip 2

Place one strip horizontally and draw lines along its edge as drawn in the figure (Fig 3.15).

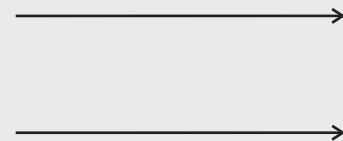

Fig 3.15

Now place the other strip in a slant position over the lines drawn and use this to draw two more lines as shown (Fig 3.16).

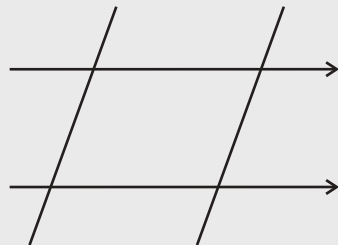

Fig 3.16

These four lines enclose a quadrilateral. This is made up of two pairs of parallel lines (Fig 3.17).

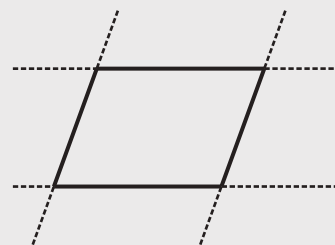

Fig 3.17

It is a parallelogram.

A parallelogram is a quadrilateral whose opposite sides are parallel.

3.4.4 Elements of a parallelogram

There are four sides and four angles in a parallelogram. Some of these are equal. There are some terms associated with these elements that you need to remember.

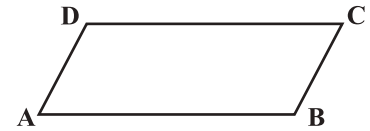

Fig 3.18

Given a parallelogram ABCD (Fig 3.18).

\overline{AB} and \overline{DC} , are **opposite sides**. \overline{AD} and \overline{BC} form another pair of opposite sides.

$\angle A$ and $\angle C$ are a pair of **opposite angles**; another pair of opposite angles would be $\angle B$ and $\angle D$.

\overline{AB} and \overline{BC} are **adjacent sides**. This means, one of the sides starts where the other ends. Are \overline{BC} and \overline{CD} adjacent sides too? Try to find two more pairs of adjacent sides.

$\angle A$ and $\angle B$ are **adjacent angles**. They are at the ends of the same side. $\angle B$ and $\angle C$ are also adjacent. Identify other pairs of adjacent angles of the parallelogram.

DO THIS

Take cut-outs of two identical parallelograms, say ABCD and A'B'C'D' (Fig 3.19).

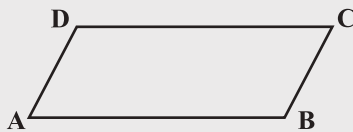
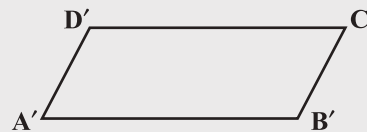

Fig 3.19



Here \overline{AB} is same as $\overline{A'B'}$ except for the name. Similarly the other corresponding sides are equal too.

Place $\overline{A'B'}$ over \overline{DC} . Do they coincide? What can you now say about the lengths \overline{AB} and \overline{DC} ?

Similarly examine the lengths \overline{AD} and \overline{BC} . What do you find?

You may also arrive at this result by measuring \overline{AB} and \overline{DC} .

Property: *The opposite sides of a parallelogram are of equal length.*

TRY THESE

Take two identical set squares with angles $30^\circ - 60^\circ - 90^\circ$ and place them adjacently to form a parallelogram as shown in Fig 3.20. Does this help you to verify the above property?

You can further strengthen this idea through a logical argument also.

Consider a parallelogram ABCD (Fig 3.21). Draw any one diagonal, say \overline{AC} .

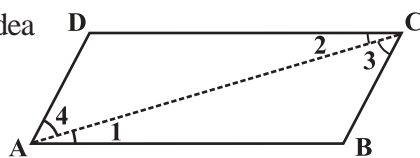

Fig 3.21

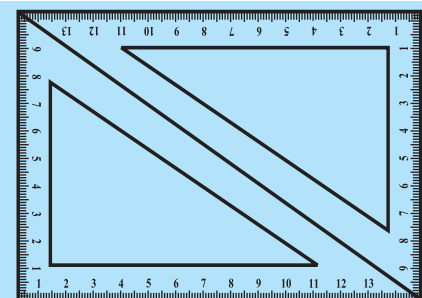

Fig 3.20

Looking at the angles,

$$\angle 1 = \angle 2 \quad \text{and} \quad \angle 3 = \angle 4 \quad (\text{Why?})$$

Since in triangles ABC and ADC, $\angle 1 = \angle 2$, $\angle 3 = \angle 4$

and \overline{AC} is common, so, by ASA congruency condition,

$$\triangle ABC \cong \triangle CDA \quad (\text{How is ASA used here?})$$

This gives $AB = DC$ and $BC = AD$.

Example 3: Find the perimeter of the parallelogram PQRS (Fig 3.22).

Solution: In a parallelogram, the opposite sides have same length.

Therefore, $PQ = SR = 12 \text{ cm}$ and $QR = PS = 7 \text{ cm}$

So, Perimeter = $PQ + QR + RS + SP$

$$= 12 \text{ cm} + 7 \text{ cm} + 12 \text{ cm} + 7 \text{ cm} = 38 \text{ cm}$$

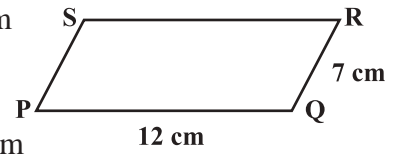

Fig 3.22

3.4.5 Angles of a parallelogram

We studied a property of parallelograms concerning the (opposite) sides. What can we say about the angles?

DO THIS



Let ABCD be a parallelogram (Fig 3.23). Copy it on a tracing sheet. Name this copy as A'B'C'D'. Place A'B'C'D' on ABCD. Pin them together at the point where the diagonals meet. Rotate the transparent sheet by 180°. The parallelograms still coincide; but you now find A' lying exactly on C and vice-versa; similarly B' lies on D and vice-versa.

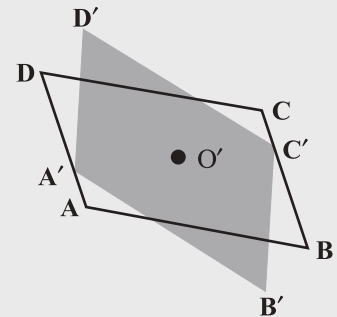

Fig 3.23

Does this tell you anything about the measures of the angles A and C? Examine the same for angles B and D. State your findings.

Property: *The opposite angles of a parallelogram are of equal measure.*

TRY THESE

Take two identical 30° – 60° – 90° set-squares and form a parallelogram as before. Does the figure obtained help you to confirm the above property?



You can further justify this idea through logical arguments.

If \overline{AC} and \overline{BD} are the diagonals of the parallelogram, (Fig 3.24) you find that

$$\angle 1 = \angle 2 \quad \text{and} \quad \angle 3 = \angle 4 \quad (\text{Why?})$$

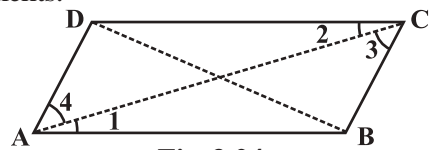

Fig 3.24

Studying $\triangle ABC$ and $\triangle ADC$ (Fig 3.25) separately, will help you to see that by ASA congruency condition,

$$\triangle ABC \cong \triangle CDA \quad (\text{How?})$$

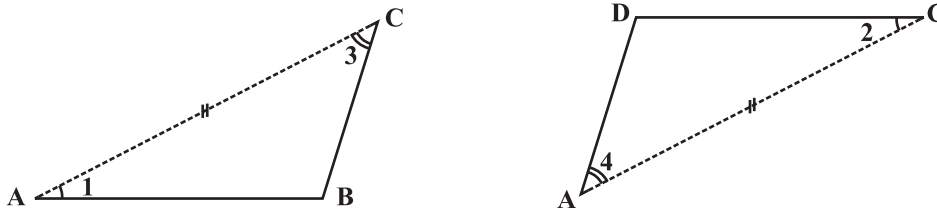

Fig 3.25

This shows that $\angle B$ and $\angle D$ have same measure. In the same way you can get $m\angle A = m\angle C$.

Example 4: In Fig 3.26, BEST is a parallelogram. Find the values x , y and z .

Solution: S is opposite to B.

- So, $x = 100^\circ$ (opposite angles property)
 $y = 100^\circ$ (measure of angle corresponding to $\angle x$)
 $z = 80^\circ$ (since $\angle y, \angle z$ is a linear pair)

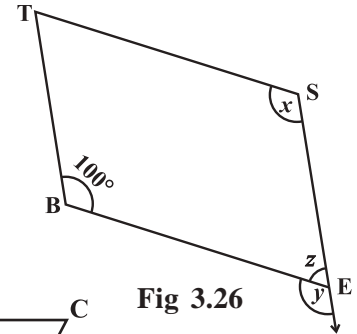

Fig 3.26

We now turn our attention to adjacent angles of a parallelogram. In parallelogram ABCD, (Fig 3.27).

$\angle A$ and $\angle D$ are supplementary since $\overline{DC} \parallel \overline{AB}$ and with transversal \overline{DA} , these two angles are interior opposite.

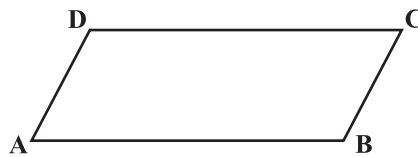

Fig 3.27

$\angle A$ and $\angle B$ are also supplementary. Can you say 'why'?

$\overline{AD} \parallel \overline{BC}$ and \overline{BA} is a transversal, making $\angle A$ and $\angle B$ interior opposite.

Identify two more pairs of supplementary angles from the figure.

Property: The adjacent angles in a parallelogram are supplementary.

Example 5: In a parallelogram RING, (Fig 3.28) if $m\angle R = 70^\circ$, find all the other angles.

Solution: Given $m\angle R = 70^\circ$
 Then $m\angle N = 70^\circ$
 because $\angle R$ and $\angle N$ are opposite angles of a parallelogram.

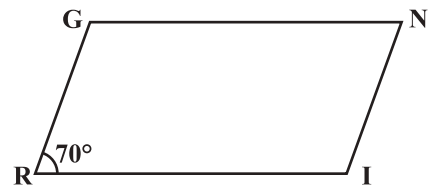

Fig 3.28

Since $\angle R$ and $\angle I$ are supplementary,

$$m\angle I = 180^\circ - 70^\circ = 110^\circ$$

Also, $m\angle G = 110^\circ$ since $\angle G$ is opposite to $\angle I$

Thus, $m\angle R = m\angle N = 70^\circ$ and $m\angle I = m\angle G = 110^\circ$



THINK, DISCUSS AND WRITE

After showing $m\angle R = m\angle N = 70^\circ$, can you find $m\angle I$ and $m\angle G$ by any other method?

3.4.6 Diagonals of a parallelogram

The diagonals of a parallelogram, in general, are not of equal length. (Did you check this in your earlier activity?) However, the diagonals of a parallelogram have an interesting property.

DO THIS



Take a cut-out of a parallelogram, say, ABCD (Fig 3.29). Let its diagonals \overline{AC} and \overline{DB} meet at O. **Fig 3.29**

Find the mid point of \overline{AC} by a fold, placing C on A. Is the mid-point same as O?

Does this show that diagonal \overline{DB} bisects the diagonal \overline{AC} at the point O? Discuss it with your friends. Repeat the activity to find where the mid point of \overline{DB} could lie.

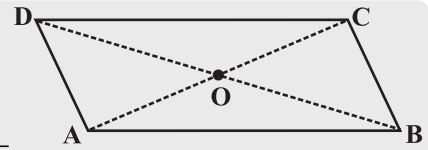

Property: The diagonals of a parallelogram bisect each other (at the point of their intersection, of course!)

To argue and justify this property is not very difficult. From Fig 3.30, applying ASA criterion, it is easy to see that

$$\triangle AOB \cong \triangle COD \quad (\text{How is ASA used here?})$$

This gives $AO = CO$ and $BO = DO$

Example 6: In Fig 3.31 HELP is a parallelogram. (Lengths are in cms). Given that $OE = 4$ and HL is 5 more than PE? Find OH.

Solution : If $OE = 4$ then OP also is 4 (Why?)

So $PE = 8,$ (Why?)

Therefore $HL = 8 + 5 = 13$

Hence $OH = \frac{1}{2} \times 13 = 6.5$ (cms)

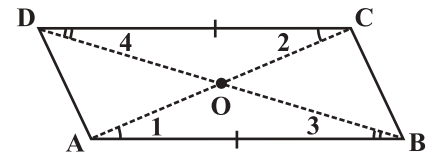

Fig 3.30

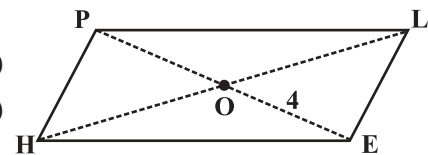

Fig 3.31

EXERCISE 3.3

1. Given a parallelogram ABCD. Complete each statement along with the definition or property used.

(i) $AD = \dots\dots$ (ii) $\angle DCB = \dots\dots$

(iii) $OC = \dots\dots$ (iv) $m\angle DAB + m\angle CDA = \dots\dots$

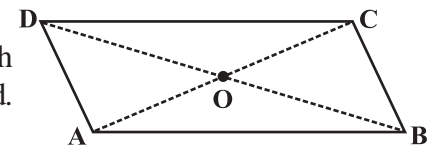

2. Consider the following parallelograms. Find the values of the unknowns x, y, z .

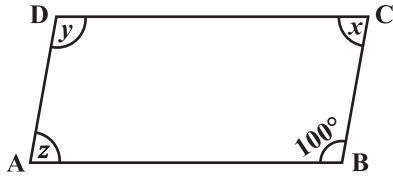

(i)

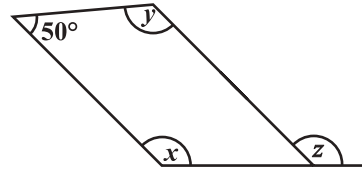

(ii)

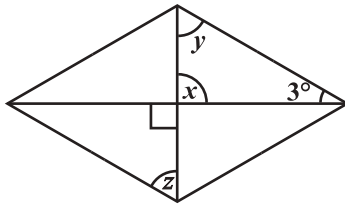

(iii)

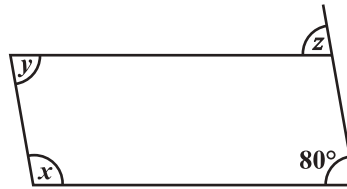

(iv)

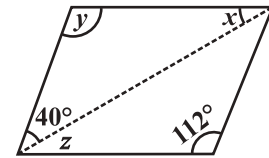

(v)

3. Can a quadrilateral ABCD be a parallelogram if
 (i) $\angle D + \angle B = 180^\circ$? (ii) $AB = DC = 8$ cm, $AD = 4$ cm and $BC = 4.4$ cm?
 (iii) $\angle A = 70^\circ$ and $\angle C = 65^\circ$?
4. Draw a rough figure of a quadrilateral that is not a parallelogram but has exactly two opposite angles of equal measure.
5. The measures of two adjacent angles of a parallelogram are in the ratio 3 : 2. Find the measure of each of the angles of the parallelogram.
6. Two adjacent angles of a parallelogram have equal measure. Find the measure of each of the angles of the parallelogram.
7. The adjacent figure HOPE is a parallelogram. Find the angle measures x, y and z . State the properties you use to find them.
8. The following figures GUNS and RUNS are parallelograms. Find x and y . (Lengths are in cm)

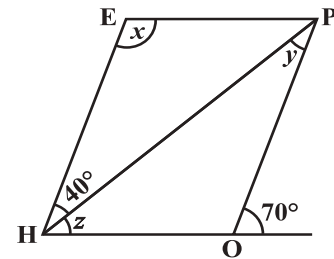

(i)

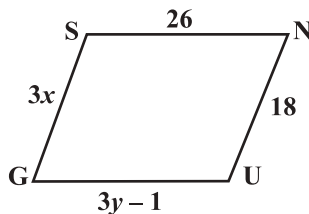

(ii)

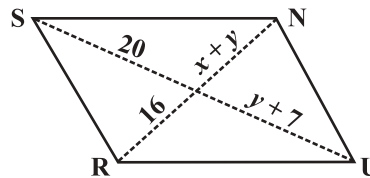

- 9.

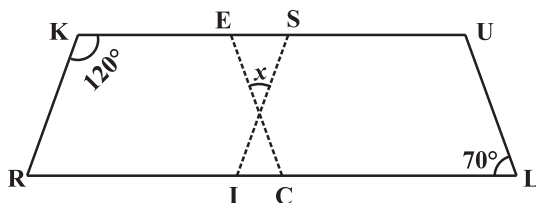

In the above figure both RISK and CLUE are parallelograms. Find the value of x .

10. Explain how this figure is a trapezium. Which of its two sides are parallel? (Fig 3.32)

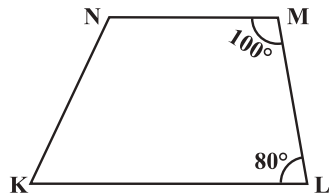

Fig 3.32

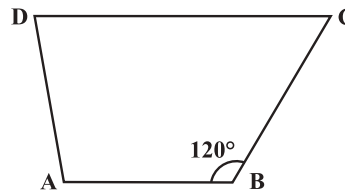

Fig 3.33

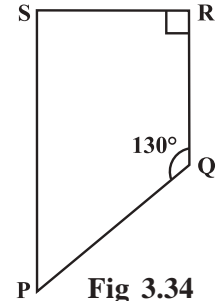

Fig 3.34

11. Find $m\angle C$ in Fig 3.33 if $\overline{AB} \parallel \overline{DC}$.
 12. Find the measure of $\angle P$ and $\angle S$ if $\overline{SP} \parallel \overline{RQ}$ in Fig 3.34. (If you find $m\angle R$, is there more than one method to find $m\angle P$?)

3.5 Some Special Parallelograms

3.5.1 Rhombus

We obtain a Rhombus (which, you will see, is a parallelogram) as a special case of kite (which is not a a parallelogram).

DO THIS

Recall the paper-cut kite you made earlier.

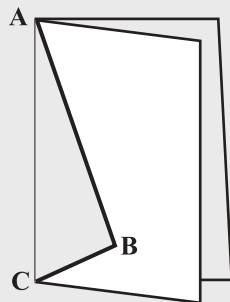

Kite-cut

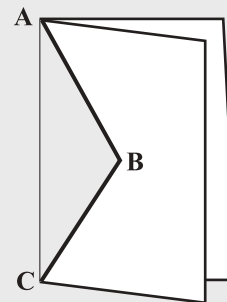

Rhombus-cut

When you cut along ABC and opened up, you got a kite. Here lengths AB and BC were different. If you draw $AB = BC$, then the kite you obtain is called a **rhombus**.

Note that the sides of rhombus are all of same length; this is not the case with the kite.

A rhombus is a quadrilateral with sides of equal length.

Since the opposite sides of a rhombus have the same length, it is also a parallelogram. So, *a rhombus has all the properties of a parallelogram and also that of a kite*. Try to list them out. You can then verify your list with the check list summarised in the book elsewhere.

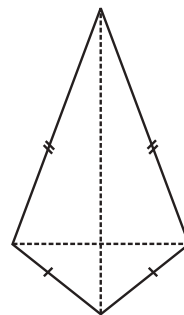

Kite

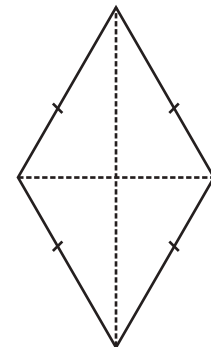

Rhombus

The most useful property of a rhombus is that of its diagonals.

Property: *The diagonals of a rhombus are perpendicular bisectors of one another.*



DO THIS

Take a copy of rhombus. By paper-folding verify if the point of intersection is the mid-point of each diagonal. You may also check if they intersect at right angles, using the corner of a set-square.

Here is an outline justifying this property using logical steps.

ABCD is a rhombus (Fig 3.35). Therefore it is a parallelogram too.

Since diagonals bisect each other, $OA = OC$ and $OB = OD$.

We have to show that $m\angle AOD = m\angle COD = 90^\circ$

It can be seen that by SAS congruency criterion

$$\Delta AOD \cong \Delta COD$$

Therefore,

$$m\angle AOD = m\angle COD$$

Since $\angle AOD$ and $\angle COD$ are a linear pair,

$$m\angle AOD = m\angle COD = 90^\circ$$

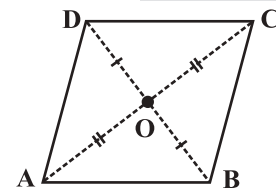

Fig 3.35

Since $AO = CO$ (Why?)
 $AD = CD$ (Why?)
 $OD = OD$

Example 7:

RICE is a rhombus (Fig 3.36). Find x, y, z . Justify your findings.

Solution:

$x = OE$	$y = OR$	$z = \text{side of the rhombus}$
$= OI$ (diagonals bisect)	$= OC$ (diagonals bisect)	$= 13$ (all sides are equal)
$= 5$	$= 12$	

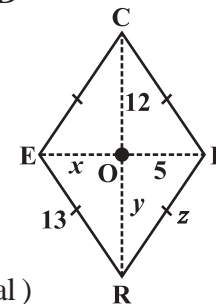

Fig 3.36

3.5.2 A rectangle

A rectangle is a parallelogram with equal angles (Fig 3.37).

What is the full meaning of this definition? Discuss with your friends.

If the rectangle is to be equiangular, what could be the measure of each angle?

Let the measure of each angle be x° .

Then $4x^\circ = 360^\circ$ (Why?)

Therefore, $x^\circ = 90^\circ$

Thus each angle of a rectangle is a right angle.

So, a rectangle is a parallelogram in which every angle is a right angle.

Being a parallelogram, the rectangle has opposite sides of equal length and its diagonals bisect each other.

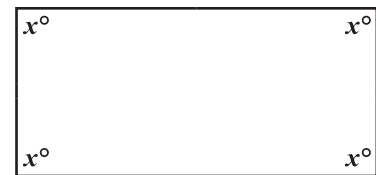

Fig 3.37

In a parallelogram, the diagonals can be of different lengths. (Check this); but surprisingly the rectangle (being a special case) has diagonals of equal length.

Property: *The diagonals of a rectangle are of equal length.*

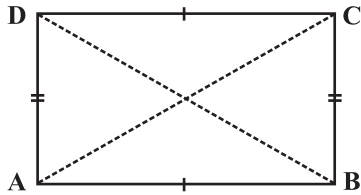

Fig 3.38

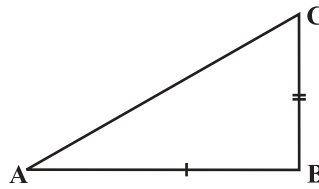

Fig 3.39

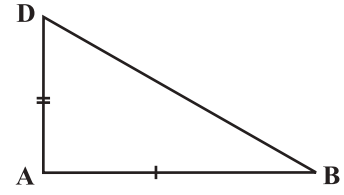

Fig 3.40

This is easy to justify. If ABCD is a rectangle (Fig 3.38), then looking at triangles ABC and ABD separately [(Fig 3.39) and (Fig 3.40) respectively], we have

$$\triangle ABC \cong \triangle ABD$$

This is because

$$AB = AB \quad (\text{Common})$$

$$BC = AD \quad (\text{Why?})$$

$$m \angle A = m \angle B = 90^\circ \quad (\text{Why?})$$

The congruency follows by SAS criterion.

Thus

$$AC = BD$$

and in a rectangle the diagonals, besides being equal in length bisect each other (Why?)

Example 8: RENT is a rectangle (Fig 3.41). Its diagonals meet at O. Find x, if $OR = 2x + 4$ and $OT = 3x + 1$.

Solution: \overline{OT} is half of the diagonal \overline{TE} ,

\overline{OR} is half of the diagonal \overline{RN} .

Diagonals are equal here. (Why?)

So, their halves are also equal.

Therefore

$$3x + 1 = 2x + 4$$

or

$$x = 3$$

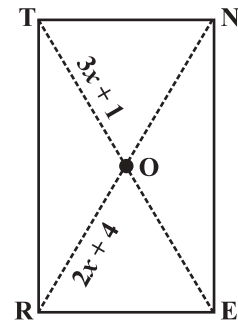

Fig 3.41

3.5.3 A square

A square is a rectangle with equal sides.

This means a square has all the properties of a rectangle with an additional requirement that all the sides have equal length.

The square, like the rectangle, has diagonals of equal length.

In a rectangle, there is no requirement for the diagonals to be perpendicular to one another, (Check this).

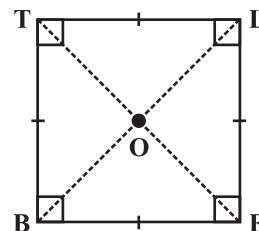

BELT is a square, $BE = EL = LT = TB$
 $\angle B, \angle E, \angle L, \angle T$ are right angles.

$BL = ET$ and $\overline{BL} \perp \overline{ET}$.

$OB = OL$ and $OE = OT$.

In a square the diagonals.

- (i) bisect one another (square being a parallelogram)
- (ii) are of equal length (square being a rectangle) and
- (iii) are perpendicular to one another.

Hence, we get the following property.

Property: *The diagonals of a square are perpendicular bisectors of each other.*

DO THIS

Take a square sheet, say PQRS (Fig 3.42).

Fold along both the diagonals. Are their mid-points the same?

Check if the angle at O is 90° by using a set-square.

This verifies the property stated above.

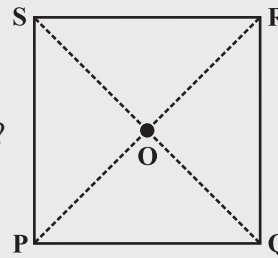

Fig 3.42



We can justify this also by arguing logically:

ABCD is a square whose diagonals meet at O (Fig 3.43).

$$OA = OC \quad (\text{Since the square is a parallelogram})$$

By SSS congruency condition, we now see that

$$\Delta AOD \cong \Delta COD \quad (\text{How?})$$

Therefore, $m\angle AOD = m\angle COD$

These angles being a linear pair, each is right angle.

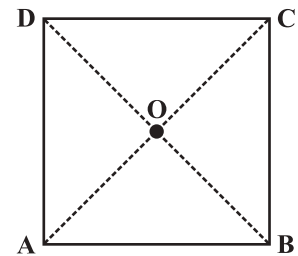

Fig 3.43

EXERCISE 3.4

1. State whether True or False.

- | | |
|---|--|
| (a) All rectangles are squares | (e) All kites are rhombuses. |
| (b) All rhombuses are parallelograms | (f) All rhombuses are kites. |
| (c) All squares are rhombuses and also rectangles | (g) All parallelograms are trapeziums. |
| (d) All squares are not parallelograms. | (h) All squares are trapeziums. |



2. Identify all the quadrilaterals that have.

- | | |
|--------------------------------|-----------------------|
| (a) four sides of equal length | (b) four right angles |
|--------------------------------|-----------------------|

3. Explain how a square is.

- | | | | |
|---------------------|----------------------|-----------------|------------------|
| (i) a quadrilateral | (ii) a parallelogram | (iii) a rhombus | (iv) a rectangle |
|---------------------|----------------------|-----------------|------------------|

4. Name the quadrilaterals whose diagonals.

- | | | |
|-----------------------|--|-----------------|
| (i) bisect each other | (ii) are perpendicular bisectors of each other | (iii) are equal |
|-----------------------|--|-----------------|

5. Explain why a rectangle is a convex quadrilateral.

6. ABC is a right-angled triangle and O is the mid point of the side opposite to the right angle. Explain why O is equidistant from A, B and C. (The dotted lines are drawn additionally to help you).

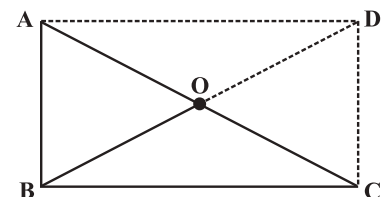



THINK, DISCUSS AND WRITE

1. A mason has made a concrete slab. He needs it to be rectangular. In what different ways can he make sure that it is rectangular?
2. A square was defined as a rectangle with all sides equal. Can we define it as rhombus with equal angles? Explore this idea.
3. Can a trapezium have all angles equal? Can it have all sides equal? Explain.

WHAT HAVE WE DISCUSSED?

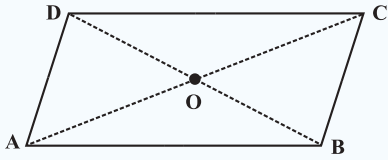
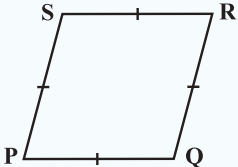
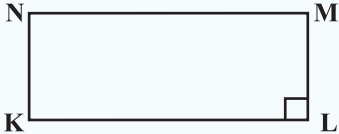
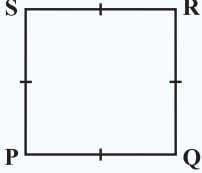
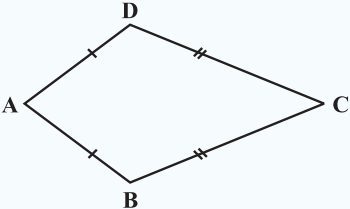
Quadrilateral	Properties
<p>Parallelogram: A quadrilateral with each pair of opposite sides parallel.</p> 	<ol style="list-style-type: none"> (1) Opposite sides are equal. (2) Opposite angles are equal. (3) Diagonals bisect one another.
<p>Rhombus: A parallelogram with sides of equal length.</p> 	<ol style="list-style-type: none"> (1) All the properties of a parallelogram. (2) Diagonals are perpendicular to each other.
<p>Rectangle: A parallelogram with a right angle.</p> 	<ol style="list-style-type: none"> (1) All the properties of a parallelogram. (2) Each of the angles is a right angle. (3) Diagonals are equal.
<p>Square: A rectangle with sides of equal length.</p> 	<p>All the properties of a parallelogram, rhombus and a rectangle.</p>
<p>Kite: A quadrilateral with exactly two pairs of equal consecutive sides</p> 	<ol style="list-style-type: none"> (1) The diagonals are perpendicular to one another (2) One of the diagonals bisects the other. (3) In the figure $m\angle B = m\angle D$ but $m\angle A \neq m\angle C$.